



**veronnesi**  
authentic italian craftsmanship



**BATHROOMS**

A SPACE FOR WELLNESS



DESIGN MAKIO HASUYKE

# BATH/ 01\_ROOM

## RIGORE E ARMONIA DI FORME

La linea e il cerchio sono un forte richiamo all'essenzialità della cultura zen.

I diversi materiali sono in equilibrio tra loro con ordine e eleganza, lo specchio e il miscelatore si fondono in un unico elemento estetico funzionale. L'essenzialità e la purezza dei materiali fanno di questo spazio, l'ambiente perfetto dove respirare benessere e rilassarsi.

## ACCURACY AND SHAPES HARMONY

*Lines and circles recall the essentials of zen culture. Find the balance and the elegance of the materials, mirror and faucet blend in one functional aesthetic element. The essential and the grace of the materials make this space perfect for relax and well-being.*



**MAKIO HASUIKE & CO**  
DESIGN





elements\_materials  
\_moduli a giorno in cristallo  
\_crystal open unit

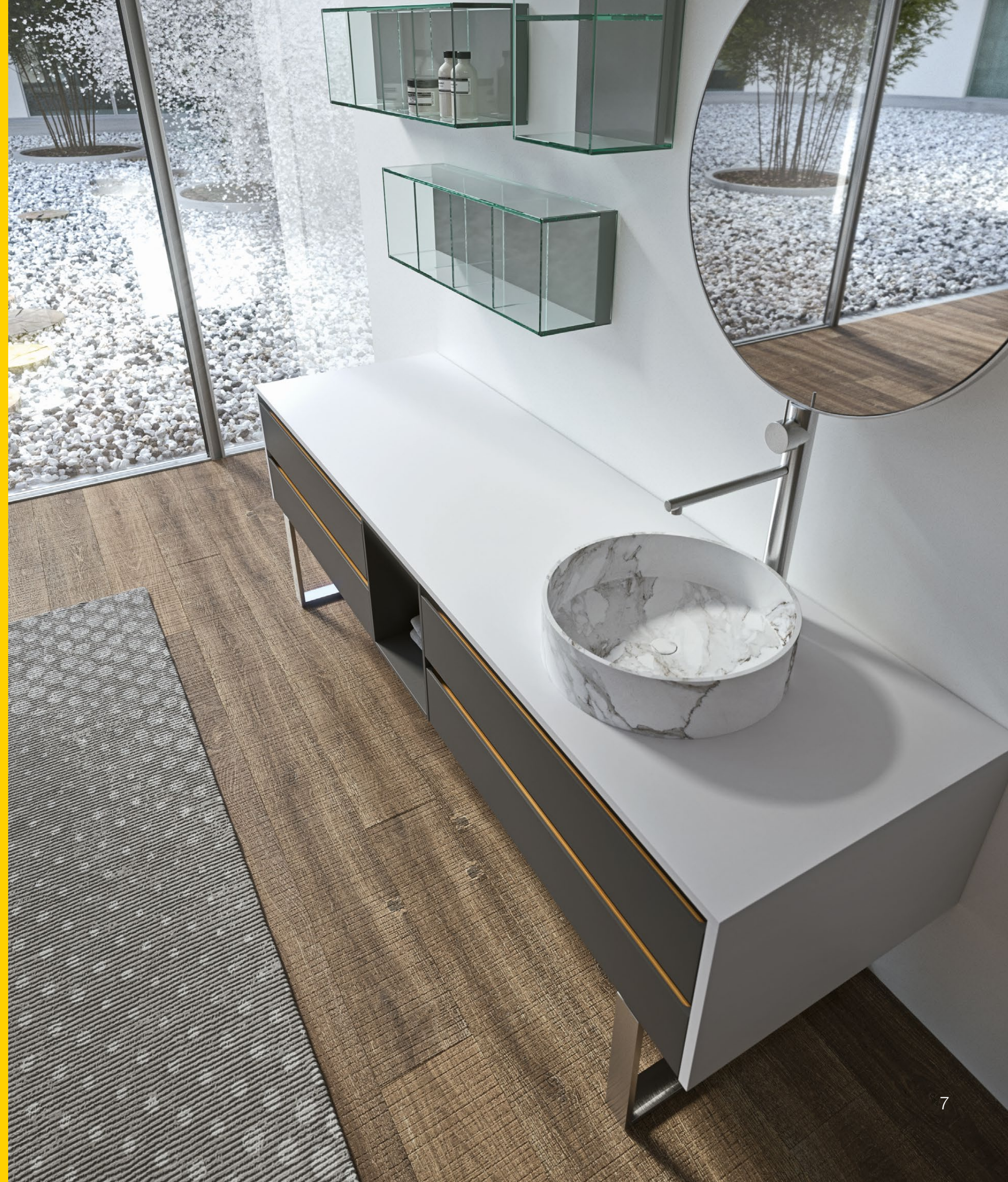



elements\_materials  
\_cassetto Grigio Orione  
\_lavabo in marmo Bianco Carrara  
\_specchio e miscelatore monoblocco

\_Orione Gray drawer  
\_White Carrara marble sink  
\_Integrated mirror and faucet in a single-piece.

DESIGN ULISSE NARCISI

# BATH/ 02\_ROOM

La forma del benessere.

Volumi dalla ricercata essenzialità, linee pulite e nette che suscitano sensazioni di semplicità e ordine. Il calore del legno sposa le candide laccature per dare vita a una sala da bagno in cui l'armonia è protagonista.

*The shape of wellness.*

*Refined essential dimensions, clear and neat lines which recall simplicity and tidiness. The warmth of the wood encounters the pure lacquered paints in a bathroom where harmony leads.*

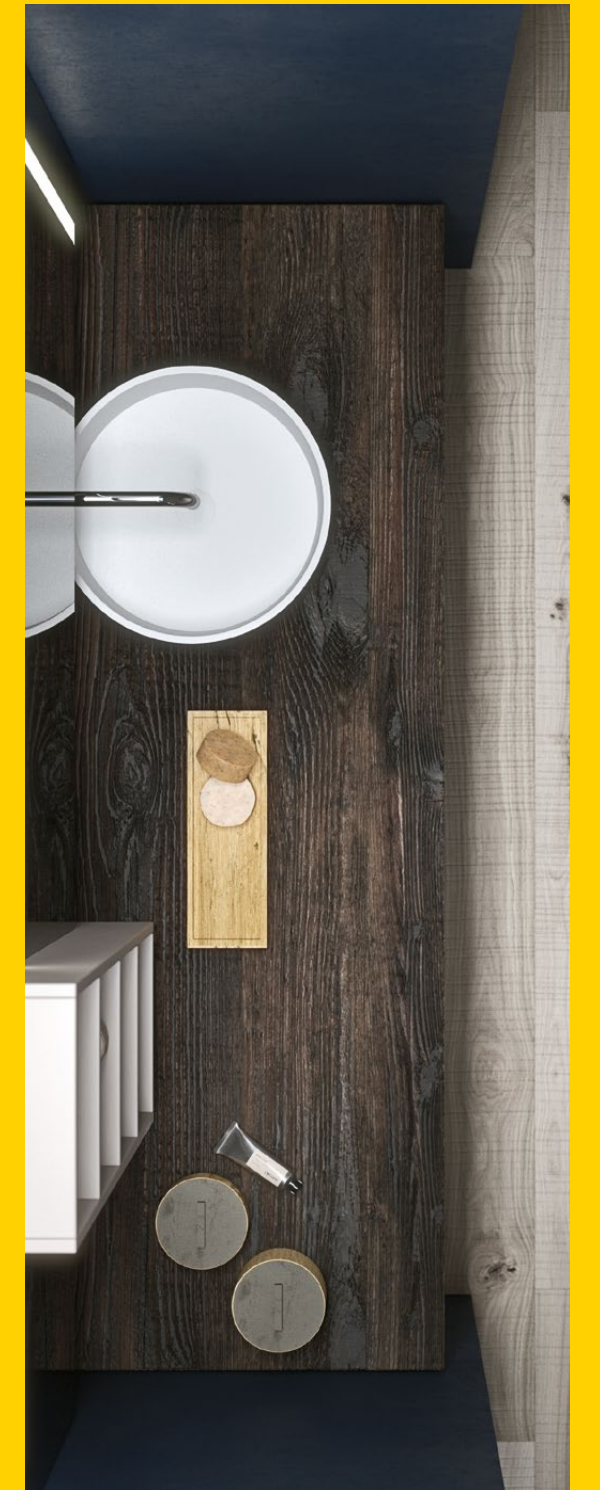





elements\_materials

- \_modulo base laccato bianco lucido
- \_modulo a giorno laccato tortora opaco
- \_specchio con fascia diffusore con LED
- \_top in legno Abete nero
- \_cassetto bianco

- \_Glossy white lacquered base unit
- \_Matt dove\_gray lacquered open unit
- \_mirror with integrated LED light strip
- \_top in e:wood black fir
- \_white drawer.





elements\_materials

\_sistema watch-it con mensole in alluminio nero

\_moduli estraibili laccati bianco lucido

\_watch-it shelf system with black aluminium shelves

\_Glossy white lacquered pull out cabinets

DESIGN ULISSE NARCISI

# BATH/ 03\_ROOM

Superfici essenziali.

La semplicità delle linee incontra la funzionalità degli spazi. Una collezione raffinata dove l'equilibrio tra superfici, spessori e materiali risulta perfetto. La pulizia formale, data dall'assenza di maniglie e sagomature, è al centro di questo concept. Tutti i moduli estraibili sono dotati di apertura a pressione.

*Essential surfaces.*

*The simplicity of the lines meets space functionality. A refined collection where surfaces, calibers and materials are perfectly balanced. The formal clearness, made of no handles, is the core concept. All drawers are equipped with push and pull opening system.*

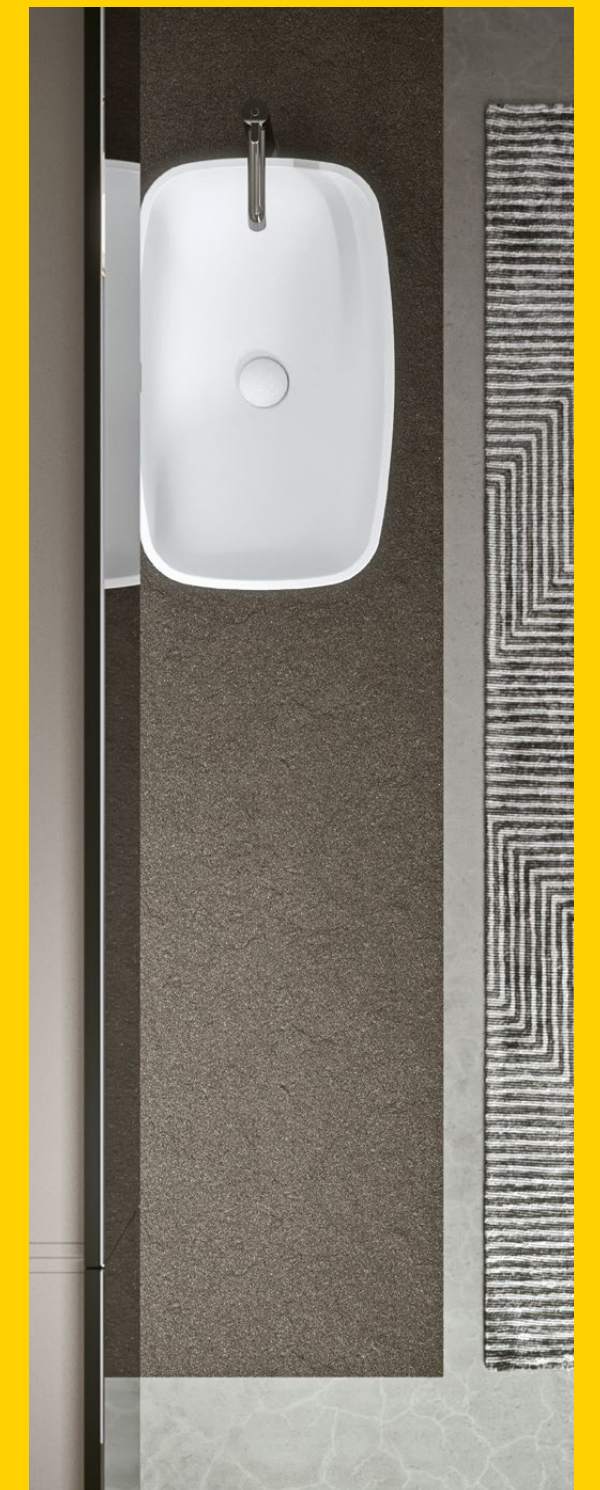





elements\_materials

\_modulo base laccato corda opaco.

\_modulo a giorno laccato visone opaco.

\_pensile Medicine Cabinet con anta a specchio grigio montata su telaio in alluminio nero.

\_Matt taupe lacquered base unit

\_Matt mink lacquered open unit

\_Medicine cabinet with mirror door mounted on a black aluminium frame.



elements\_materials

- \_pensili e mensole laccato corda opaco.
- \_top in quarzite K-Proof Pacific grey fiammato.
- \_lavabo in ceramica

- \_Matt taupe lacquered wall cabinets and shelves.
- \_K-proof Pacific shot gray quartz Top.
- \_ Ceramic sink.



DESIGN ULISSE NARCISI

# BATH/ 04\_ROOM

Materiali in continuità.

Il calore del legno incontra l'eleganza del grès e, insieme, esaltano la bellezza del vetro, convivendo in perfetta armonia.

Top e lavabo, concepiti in un unico blocco saldato, donano continuità all'intera composizione, mentre la grande superficie in vetro è perfetta per esaltare lo spazio e riflettere l'armonia di tutti i materiali in gioco.

*Materials in succession.*

*The warmth of wood encounter the elegance of porcelain and, together, enhance the beauty of glass, living together in perfect harmony.*

*Top and sink, welded in a single piece element, give continuity to the whole composition, while the big mirror surface reflects the balance of all materials put together.*

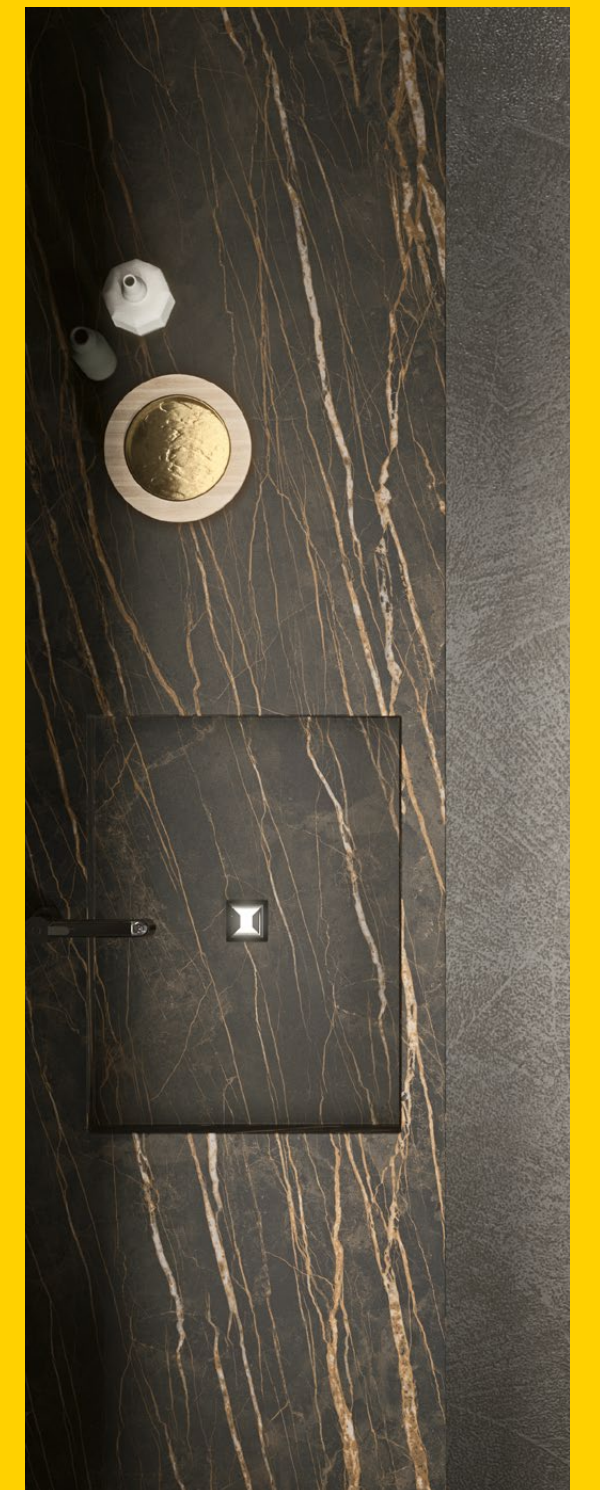





elements\_materials

\_anta Acuta in rovere nodato fumè

\_gola concava testa di moro

\_Acuta door in smokey knotted oak veneer

\_dark brown c-channel





elements\_materials:  
\_rovere nodato fumè  
\_top e lavabo in Laminam Cava Noire desir  
\_pensile Medicine Cabinet con anta a specchio grigio montata su telaio in alluminio nero  
  
\_smokey knotted oak veneer  
\_Top and sink in Laminam Cava Noire desir  
\_Wall medicine cabinet with gray mirror door on a black aluminium frame.



elements\_materials:

\_pensili con anta a specchio grigio su telaio in alluminio nero  
\_mensole rovere nodato fumè.

\_Wall cabinets with gray mirror door on a black aluminium frame.  
\_Smokey knotted oak shelves



DESIGN ULISSE NARCISI

# BATH/ 05\_ROOM

Volumi e trasparenze.

Un concept bagno essenziale ma ricco di materiali ricercati. La perfetta uniformità delle superfici in Fenix esalta la bellezza dello spesso top in larice, mentre il volume trasparente del modulo con anta in vetro, definisce un'inedita geometria dello spazio. Giochi di trasparenze e sovrapposizioni materiche introducono in una vera e propria oasi di benessere.

*Volume and transparency.*

*A bath concept which is essential but rich in refined materials. The perfect homogeneity of Fenix surfaces enhances the beauty of the thick larch top, while the transparent unit with glass door, defines a brand new space layout.*

*Games of transparencies and overlapping materials introduce us to a real wellness oasis.*







Modulo incassato a parete  
 \_anta con telaio alluminio Metal Brown in alluminio e vetro fumè (Bright)  
 \_interno in LPL Noce Caracalla  
 \_mensole in vetro con profilo in alluminio e illuminazione led

Wall built in column  
 \_door with Metal Brown aluminium and smoked glass (Bright)  
 \_Interior structure in LPL Caracalla walnut  
 \_glass shelves with aluminium profile and Led lighting





elements\_materials:

- \_moduli estraibili con ante e top in Fenix Bianco Alaska
- \_moduli a giorno laccato visone opaco
- \_piano di appoggio in E-wood larice H. 8cm
- \_lavello in ceramica

- \_pull out units with front and top in Alaska white Fenix
- \_Matt mink lacquered open units
- \_top in E-wood larch H. 8 cm.
- \_ceramic sink

DESIGN ULISSE NARCISI

# BATH/ 06\_ROOM

La forma della funzione.

Uno spazio essenziale, in cui ogni dettaglio assume la massima praticità. Assoluto protagonista di questo ambiente è il top in Corian con i due lavabi saldati, massima espressione di linearità e purezza formale. Funzionalità ed estetica convivono alla perfezione, caratterizzando ogni vano e ogni superficie, con equilibrio e grazia.

*The shape of functionality.*

*An essential space, where each detail becomes absolutely practical.*

*The Corian top, with its two welded sinks, plays a leading role, representing linearity and formal clearness. Functionality and aesthetic are perfectly blended, giving balance and grace to each compartment.*

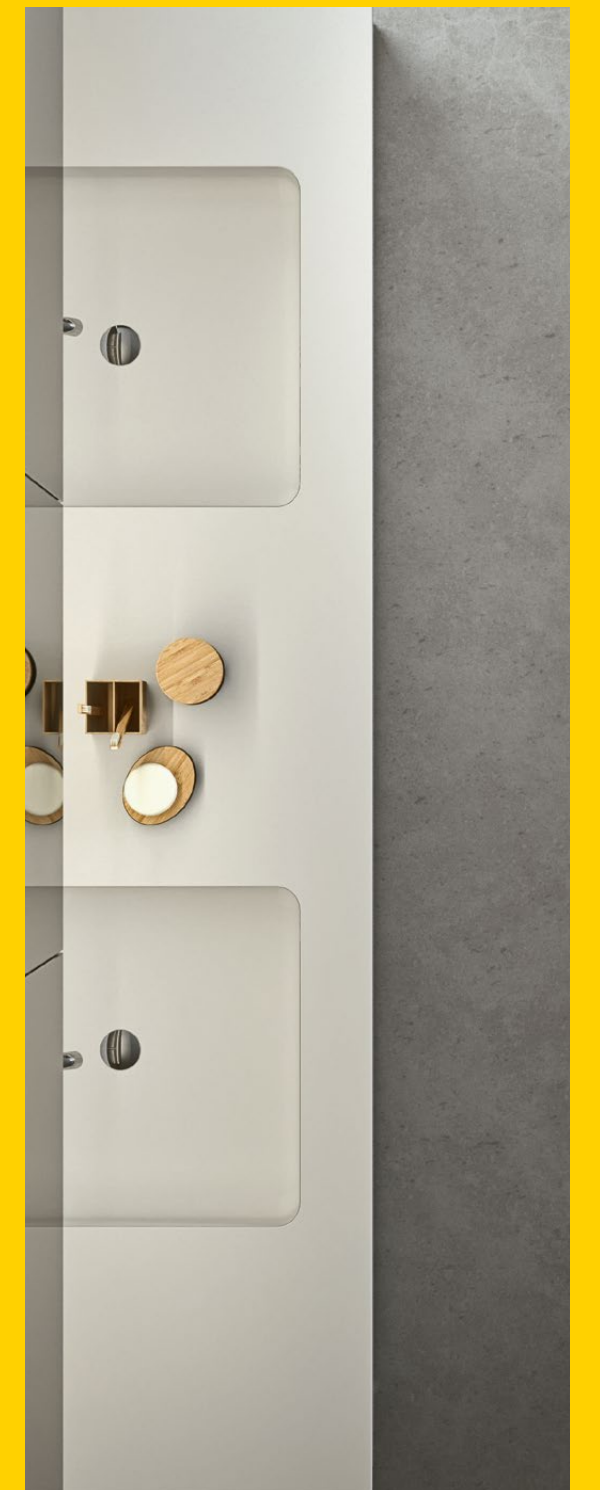





elements\_materials:  
\_pensili in PET grigio beton  
\_moduli a giorno laccato grigio grafite opaco  
  
\_Beton gray PET wall cabinets  
\_Matt Graphite gray lacquered open units





elements\_materials:

\_moduli base con anta profilo 90° nero in PET grigio beton;

\_top in corian con lavabi saldati

\_pensile "medicine cabinets" con anta a specchio montata su telaio in alluminio nero.

\_Beton gray Pet base cabinets with 90° black profile door

\_corian Top with welded sinks

\_Wall Medicine cabinets with mirror door on a black aluminium frame



DESIGN ULISSE NARCISI

# BATH/ 07\_ROOM

Originalità funzionale.  
Volumi e materiali giocano tra loro creando uno spazio estremamente fantasioso. I moduli e i pensili dalle linee essenziali fanno da sfondo ai due lavabi in Corian montati a terra. Un concept che punta all'originalità e alla simmetria senza mai perdere di vista la praticità.

*Functional originality.  
Volumes and materials play together creating an extremely fantasy space. Wall units and wall cabinets are the background of two free-standing Corian sinks. This concept pull together originality and practicality.*







elements\_materials:

- \_moduli base e pensile laccati grigio grafite opaco
- \_moduli a giorno laccati grigio grafite opaco
- \_lavabo a terra in Corian

- \_Matt graphite gray lacquered base and wall cabinets
- \_Matt graphite gray lacquered open units
- \_free-standing Corian sink





elements\_materials:

\_pensili con apertura a pressione in HPL Grigio monsoone

\_HPL monsoon gray wall cabinets with push and pull opening system.

# BATH/ 08\_ROOM

Stile e relax.

Il bagno moderno deve essere un ambiente rilassante dove ogni aspetto, dalla progettazione degli spazi alla scelta degli arredi, deve saper soddisfare le esigenze di chi ne usufruisce, diventando piena espressione di uno stile vero e proprio. Ciò si ottiene non solo attraverso spazi ampi e luminosi ma soprattutto con la giusta scelta di arredi e materiali.

*Style and relax.*

*A modern bathroom has to be a relaxing environment where each step, from space projecting to furniture design, must satisfy the customer needs, becoming expression of a unique style. This can be accomplished by having wide and bright spaces but mostly through an accurate selection of the right piece of furniture and the right materials.*

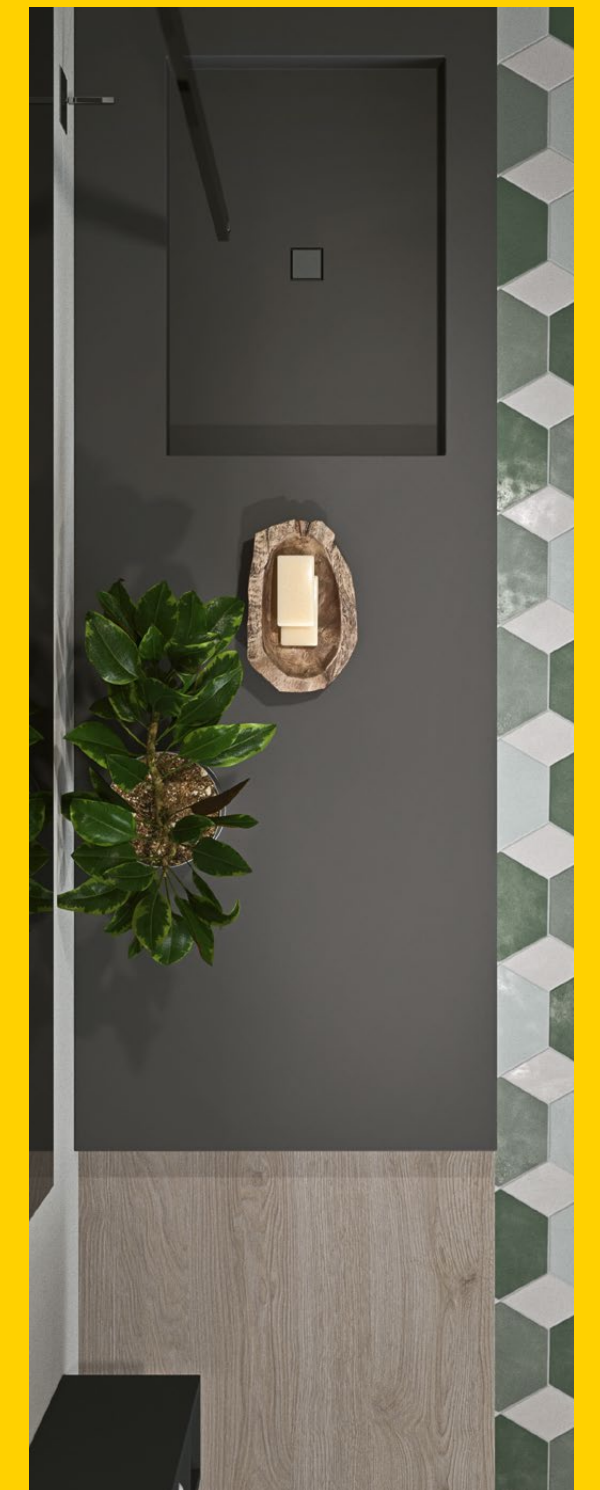





elements\_materials:

\_moduli base rovere cenere

\_top in Fenix Grigio Bromo con lavabo integrato

\_Ash oak LPL base cabinets

\_Bromine gray Fenix top with built-in sink





elements\_materials:  
\_moduli a giorno laccati grigio londra opaco \_tortora opaco  
\_Matt London gray lacquered\_Matt dove-gray open units

DESIGN ULISSE NARCISI

# BATH/ 09\_ROOM

L'eleganza della tradizione.

Il fascino di un ambiente dal respiro classico rimane indiscusso. Il perfetto connubio tra tradizione e innovazione trova la sua massima espressione nelle lavorazioni artigianali impreziosite dal marmo, capace di trasmettere intense sensazioni tattili e visive.

*The elegance of tradition.*

*The charm of a classic environment remains undisputed. The perfect bond between tradition and innovation finds its expression in handcrafted works enriched by marble, which gives intense tactile and visual feelings.*







elements\_materials:  
\_consolle laccata bianco canapa opaco con decorazioni in oro;  
\_top in marmo Calacatta;  
\_lavabo in ceramica  
  
\_Matt hemp white lacquered consolle with gold decorations;  
\_Calacatta marble top  
\_ceramic sink





elements\_materials:  
\_decorazioni in oro;  
\_gold decorations;

FINITURE



**veronnesi**  
authentic italian craftsmanship

# ANTE

## Anta LPL

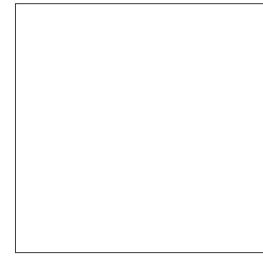

Bianco luna 0U0

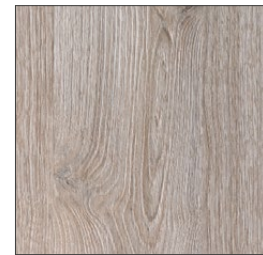

Rovere cenere 0AM

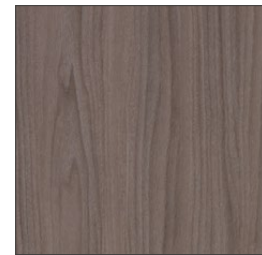

Noce 0RW



Noce scuro 0RU



Rovere Bruges tranchè 0T8

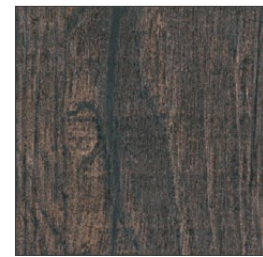

Quercia moka 0C7



Quercia mandorla 0C8



Quercia avena 0C9

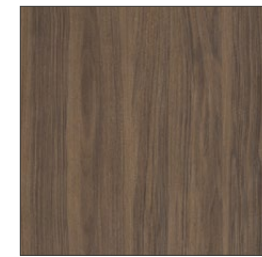

Noce caracalla UM

## Anta PET lucido e opaco

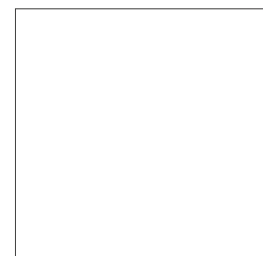

Bianco segnale 0BV 0DO



Tele grigio 0ZC 0ZD

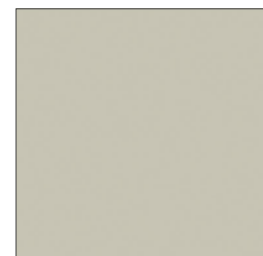

Grigio seta 0AH 0AR



Grigio beton 0SZ 0RZ

# ANTE

## Anta MDF laccata lucida e opaca

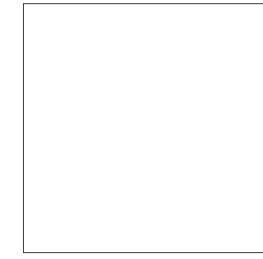

Bianco assoluto 0NS 0NR

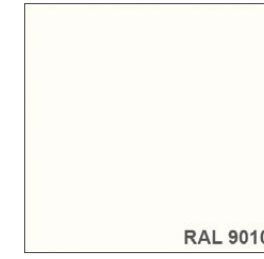

Bianco puro 061 005



Grigio oliva 0AS 052

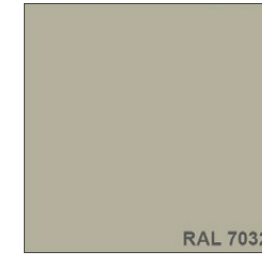

Grigio siliceo 0CU 031



Corda 0GH 033



Tortora 0GI 075



Visone 0GM 0G9



Blu zaffiro 0OD 0NV



Grigio grafite 0GG 0G8



Blu verde 0EY 0CQ

# ANTE

## Essenze legno



Rovere fumè 00S



Rovere sabbia 00R



Rovere moka 0GW



Noce canaletto 0DE



Rovere termotrattato spazzolato 0NY



Grafite 048



Rovere naturale 0D0



Rovere nodato sabbia 00T



Rovere nodato fumè 00U



Rovere nodato moka 00V

# ANTE

## Fenix NTM

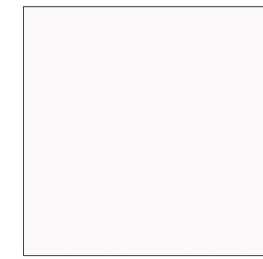

Bianco Alaska 0BW

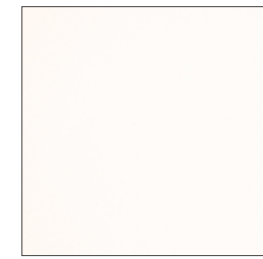

Bianco Malè 0SU

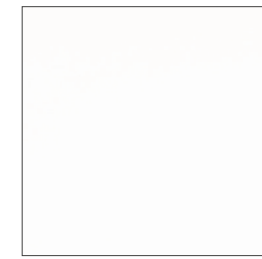

Bianco Kos 0UO

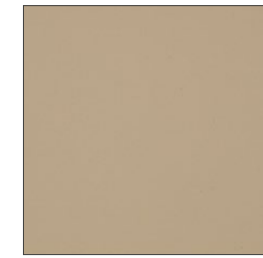

Beige Luxor 0M4



Castoro Ottawa 0C0



Grigio Londra 0CW



Alluminio 0AL



Grigio Efeso 0K9



Grigio Bromo 0MV



Nero Ingo 0DW

# ANTE

## Ante a vetro

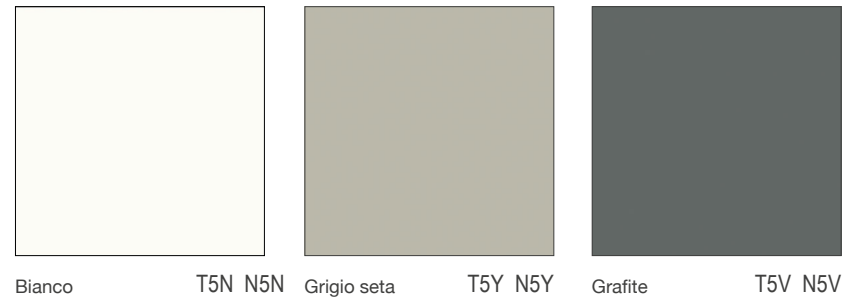

## Ante a specchio

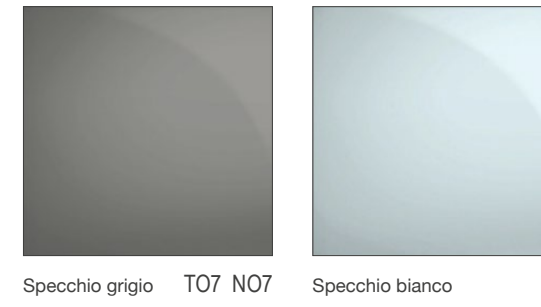

TOP

Top laminato bordo ABS Twenty h. 2 cm - Forty h. 4 cm - Sixty h. 6 cm

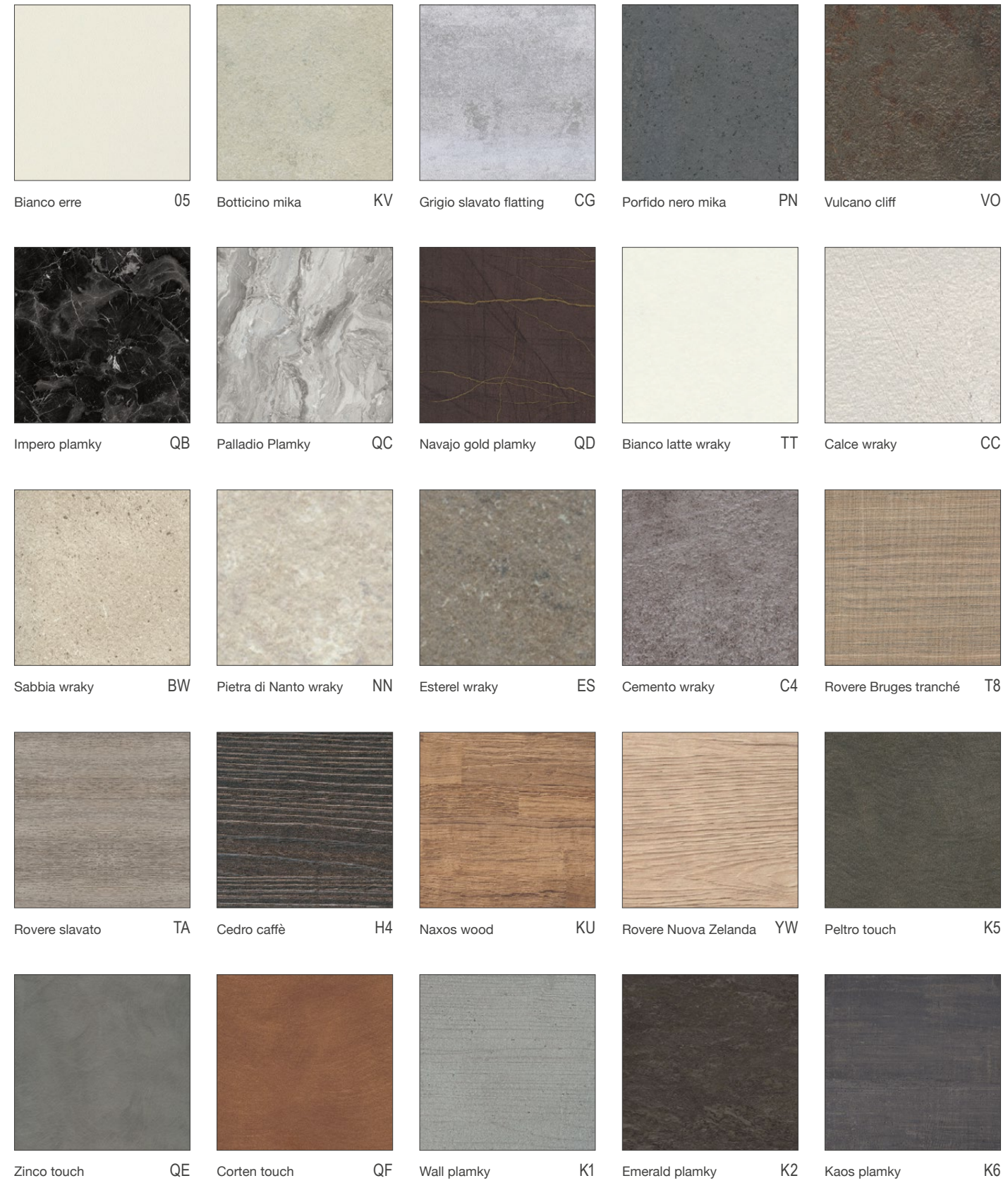

TOP

Top Fenix NTM™ h. 1,2/2/4/6 cm

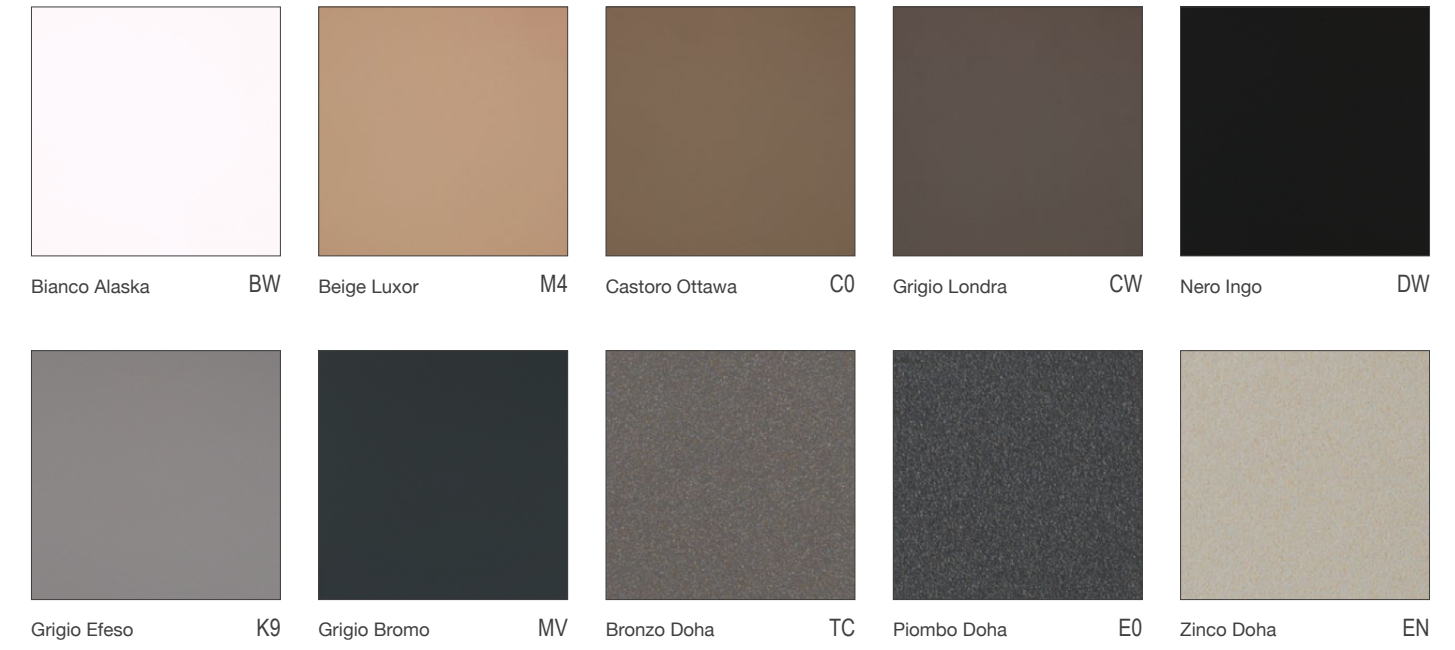

# TOP

Top DuPont™ Corian® h. 2/3/4/6 cm

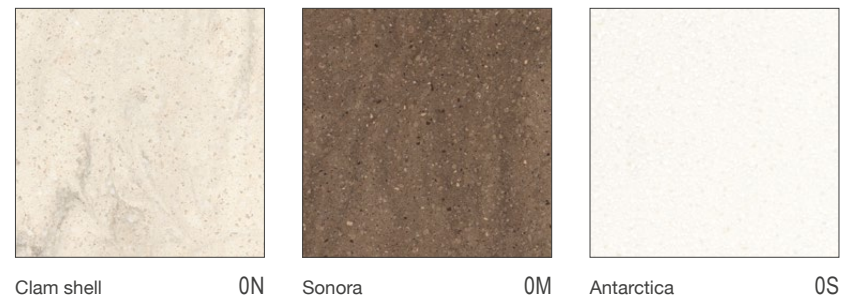
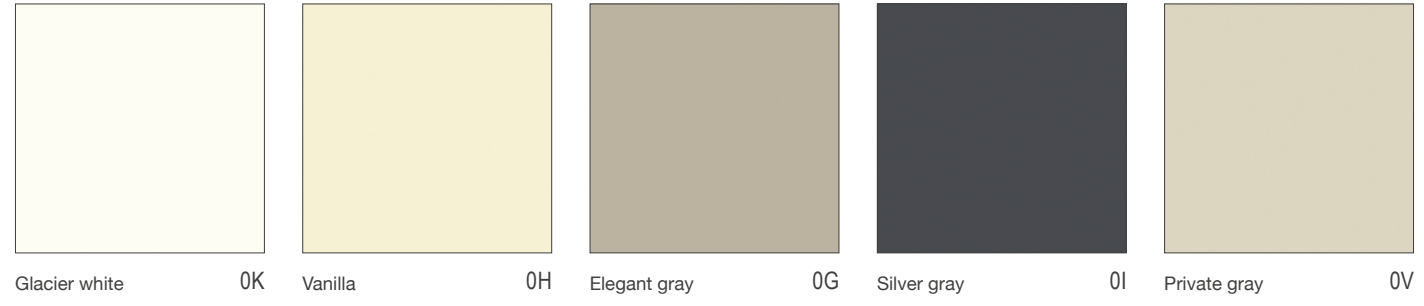

# TOP

Top sintetico SMART h. 2/3/4/6 cm



# TOP

Top grès Laminam® h. 1,2 cm



Calce bianco WH



Calce avorio WL



Calce tortora WM

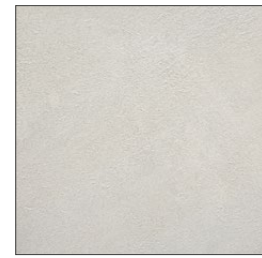

Calce grigio WN



Calce antracite WO



Calce nero WP



Pietra di Savoia grigia NL

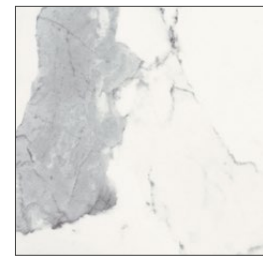

Bianco statuario soft touch WQ



Calacatta oro soft touch WR



Ossido bruno WT



Ossido nero WU

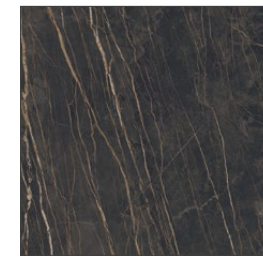

Cava Noir Desir SF

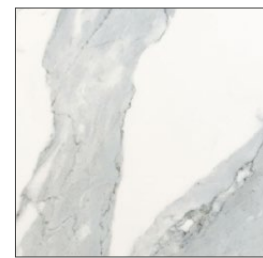

Bianco statuario lucidato WW

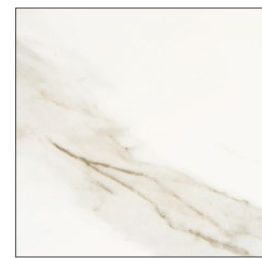

Calacatta oro lucidato WY



Neve Lucidato WZ

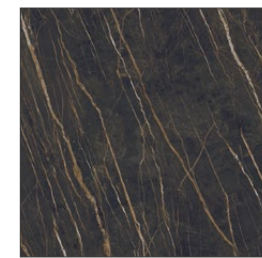

Cava Noir Desir lucidato SG



Cava Nero Greco lucidato SH

# TOP

Top in Silestone® h. 2/3/4/6 cm



Blanco Norte C5 L/S



Gris expo C7 L/S

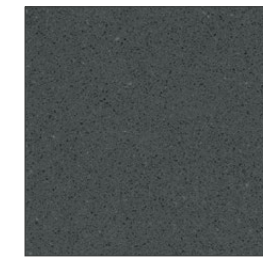

Marengo RQ L/S



Rogui C9 L/S



Noka C8 L/S

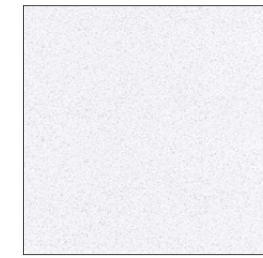

White storm C1 L/S



Nymbus KA L/S

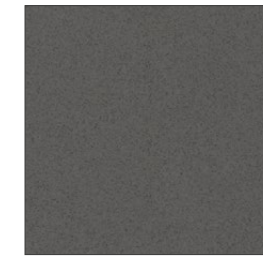

Cemento C4 L/S

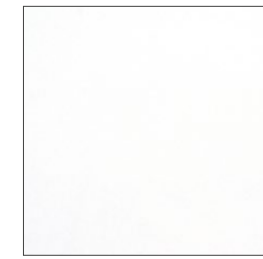

Blanco zeus A3 L/S

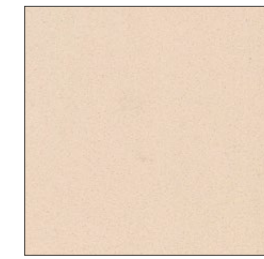

Haiku A4 L/S



Tigris sand A6 L/S



Unsui A8 L/S



Amazon A0 L/S



Kensho A5 L/S

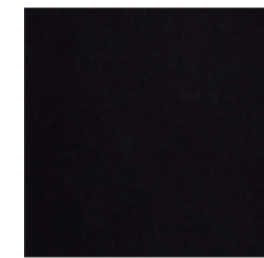

Iconic black RS L/S

# TOP

Top in Silestone® h. 2/3/4/6 cm

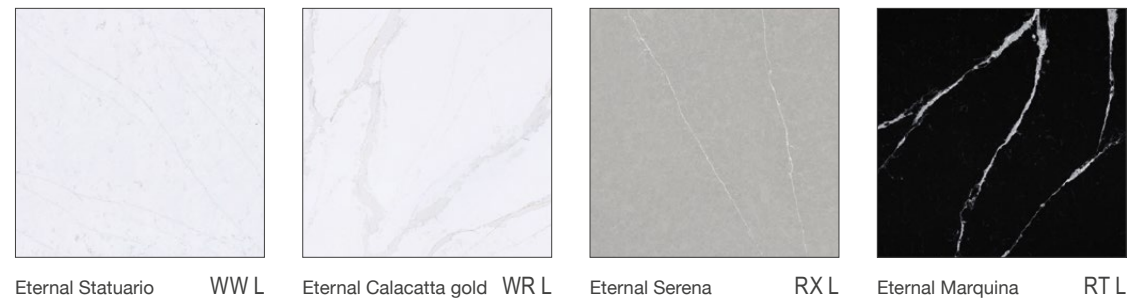
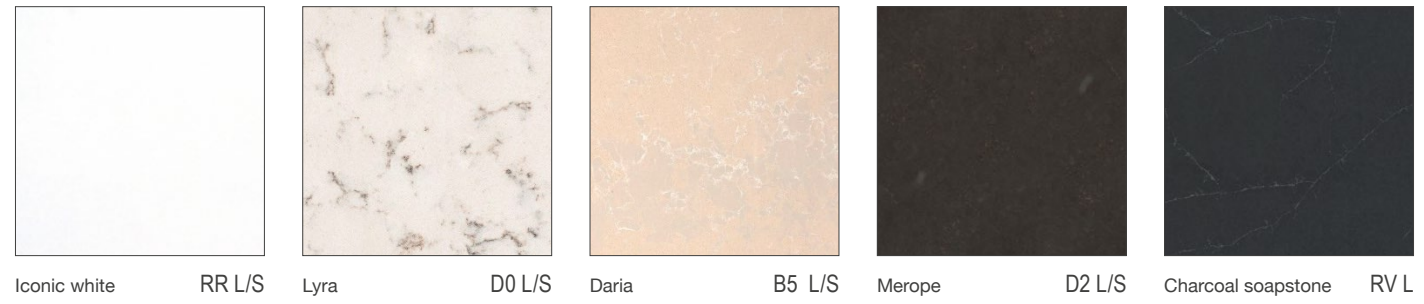

Top quarzite K Proof® h. 2/4/6 cm

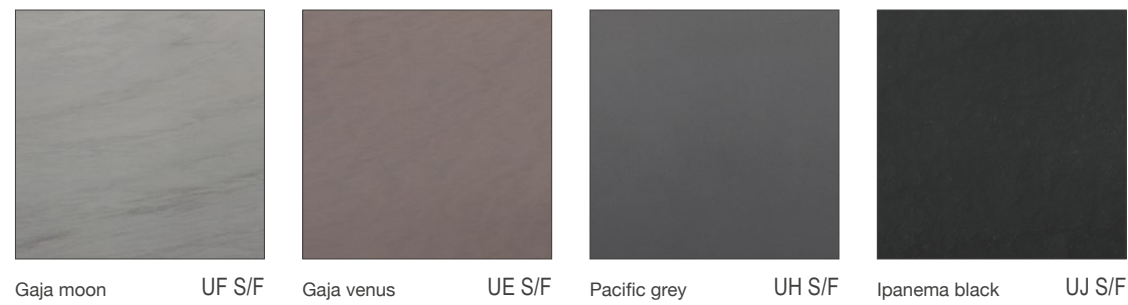

# TOP

Top marmi e graniti h. 3/6 cm

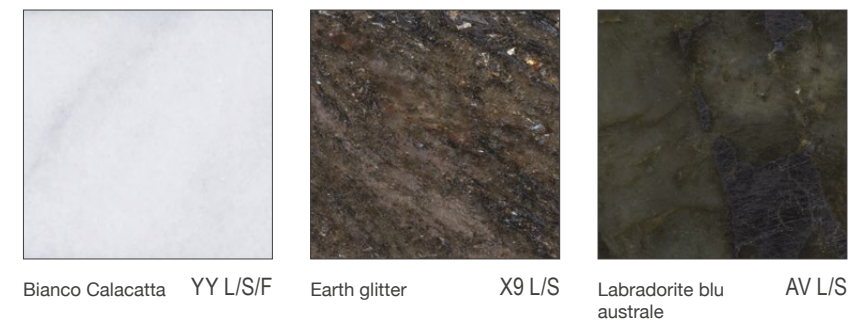
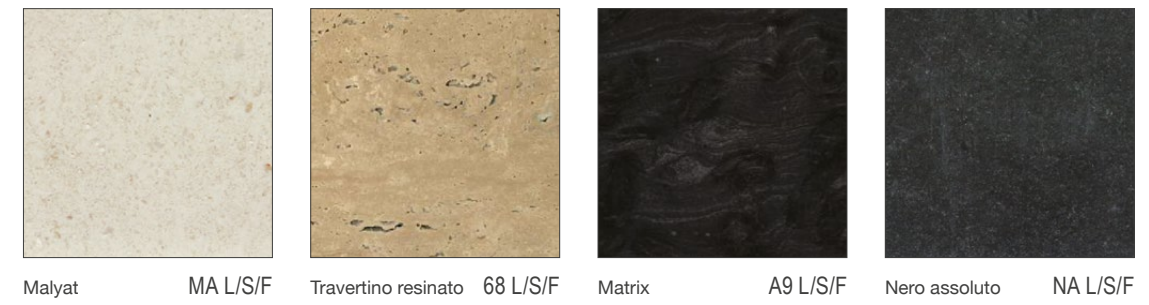

# TOP

Top in Silestone® h. 2/3/4/6 cm

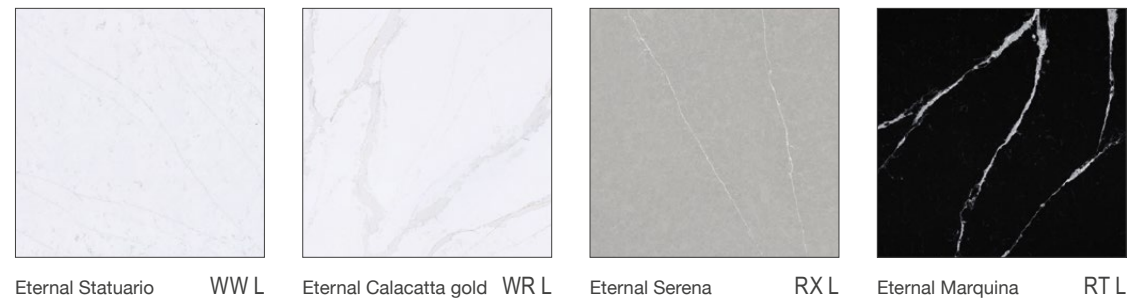
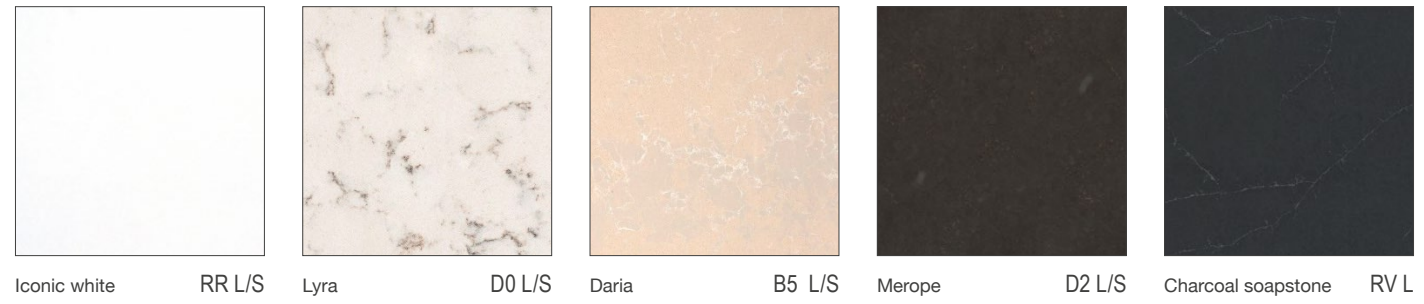

Top Portland: h. 2/4/6 cm

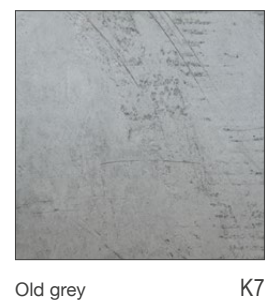

# TOP

Top in vetro h. 1,5 cm

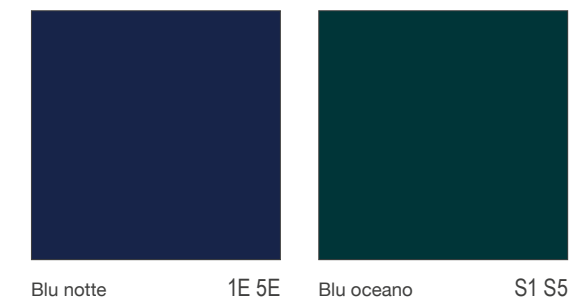
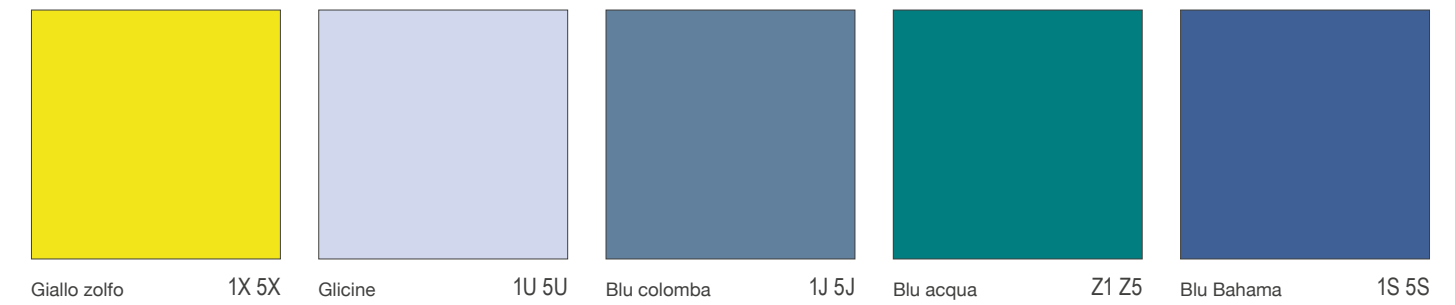
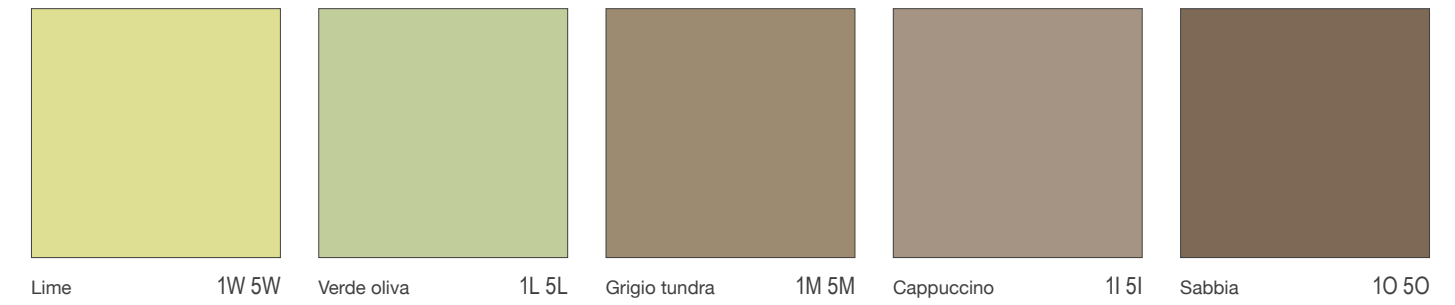
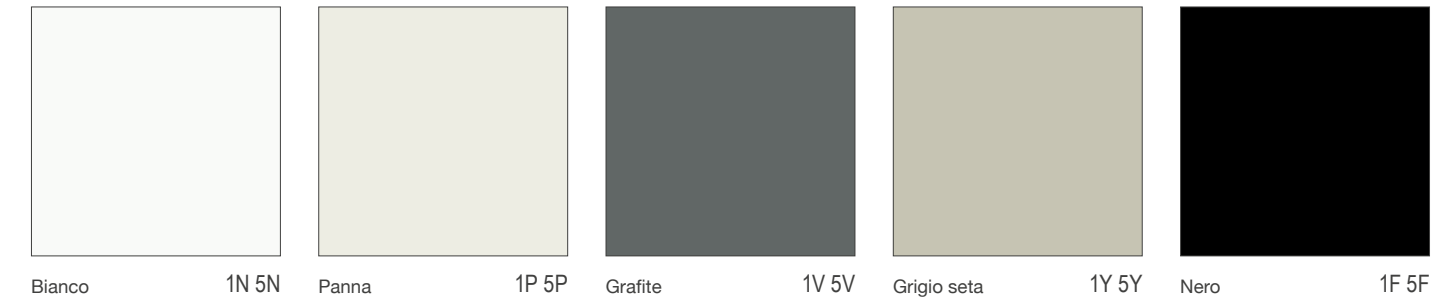

# TOP

Top impiallacciato in legno h. 1,8/2,8/6/8 cm



Rovere termotrattato spazzolato DH  
Noce canaletto DE  
Rovere nodato moka



Rovere nodato tranchè PY  
Rovere nodato sabbia OT  
Rovere nodato fumè OU

# TOP

Top e:wood h. 6/8 cm



Natural D9  
Anticato E6

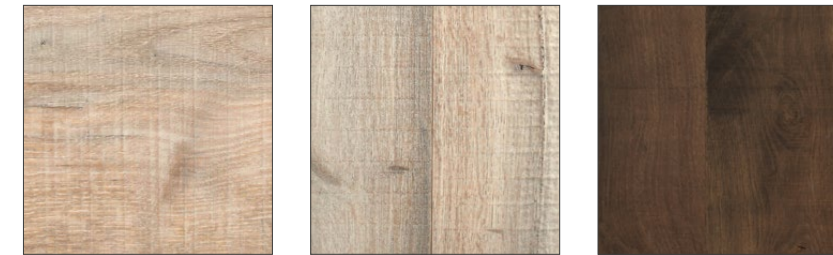

Olbia F0  
Venezia XC  
Aosta XD



Abete nero NAB  
Quercia NAC  
Larice NAD

# TOP

Top in Dekton® h. 2 cm



Danae ZU Sirocco ZY Kadum ZJ Sirius Z7 Edora Z8

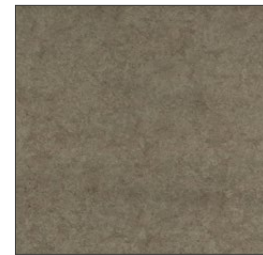

Vegha W0

# TOP

Top in Dekton® h. 2 cm



Keon SC Domoos ZW Keranium W2 Kelya W4 Makai W5

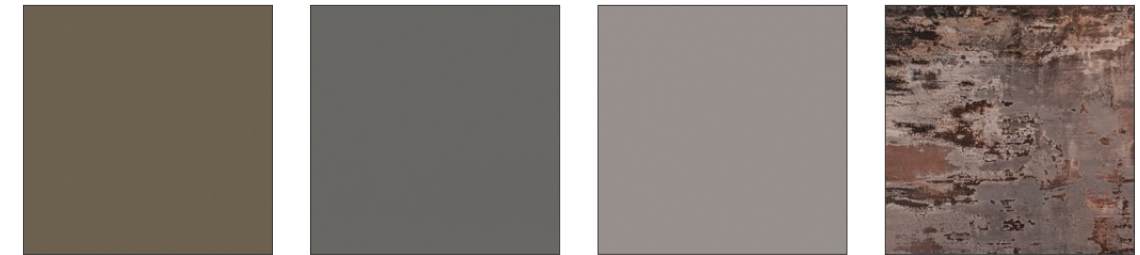

Galema W6 Korus W8 Ventus W9 Trilium WA

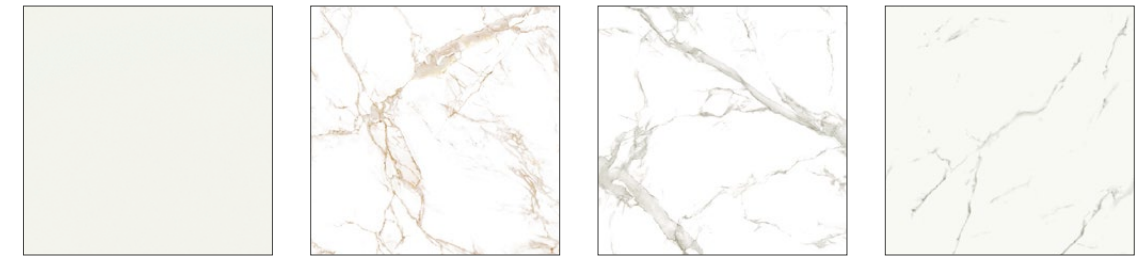

Zenith Z2 Entzo WB Aura WC Kairos WD

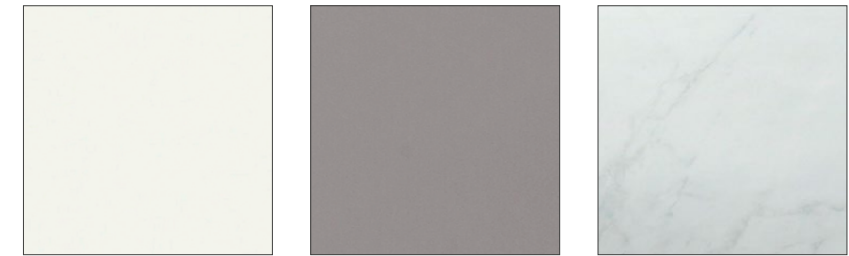

Halo WE Splendor WF Tundra WG

# PIANI IN FOLDING CON VASCA LAVELLO



**veronnesi**  
authentic italian craftsmanship

# PIANO IN FOLDING CON VASCA LAVELLO

Universal 14

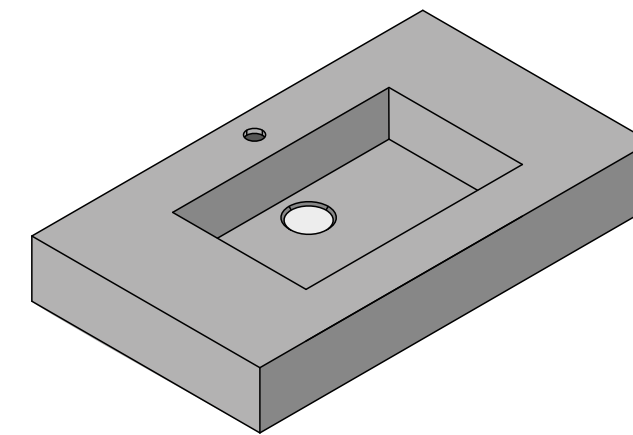

VASCA CENTRATA

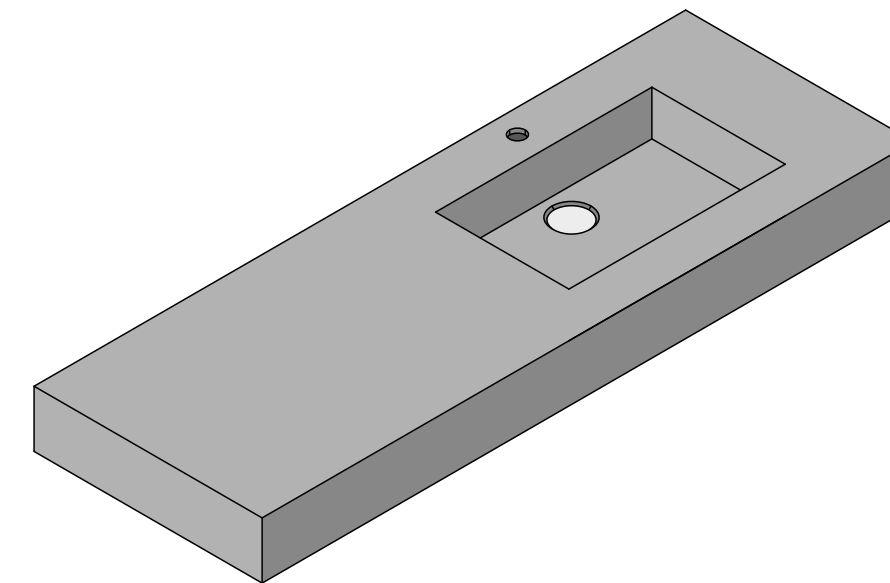

VASCA DECENTRATA

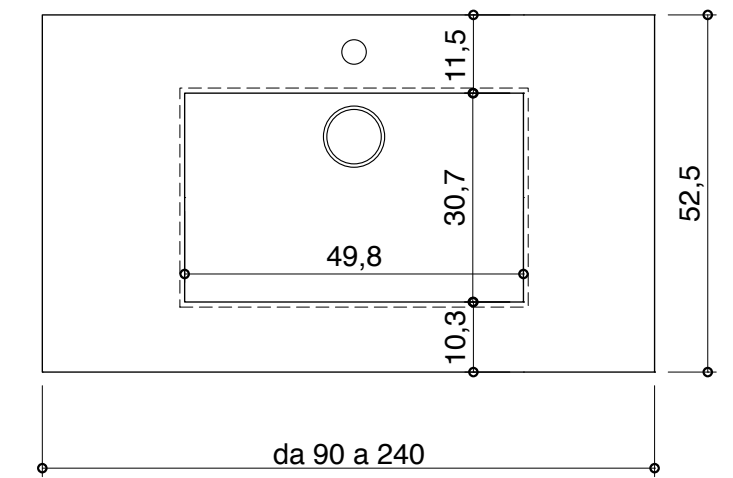

TOP VIEW



FRONT VIEW

## PIANI IN FOLDING CON VASCA LAVELLO

### Laminato HPL



Mizar

Avana

Sidney

Nassau



Vison

Forest

Brock

Karbon

## PIANI IN FOLDING CON VASCA LAVELLO

### Laminato HPL

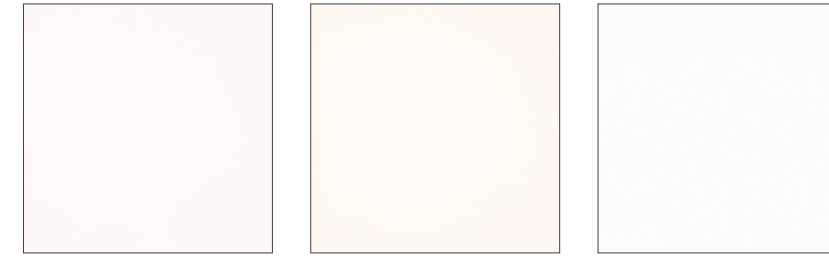

Bianco Alaska

0BW

Bianco Malè

0SU

Bianco Kos

0UO



Beige Luxor

0M4

Castoro Ottawa

0C0

Grigo Londra

0CW

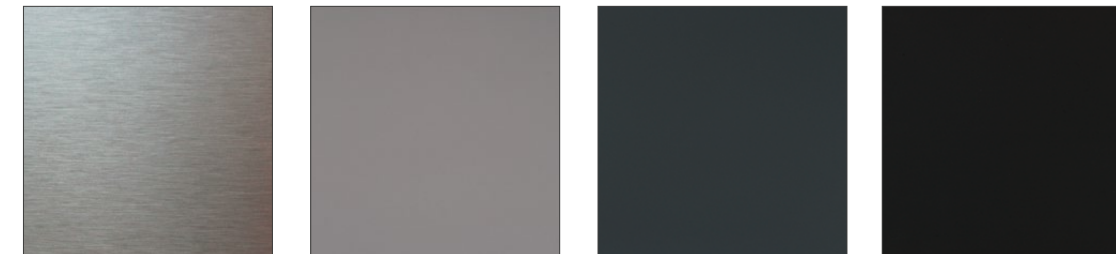

Alluminio

0AL

Grigio Efeso

0K9

Grigio Bromo

0MV

Nero Ingo

0DW

# LAVELLI IN CORIAN



**veronnesi**  
authentic italian craftsmanship

LAVELLI IN CORIAN

Bowl 400

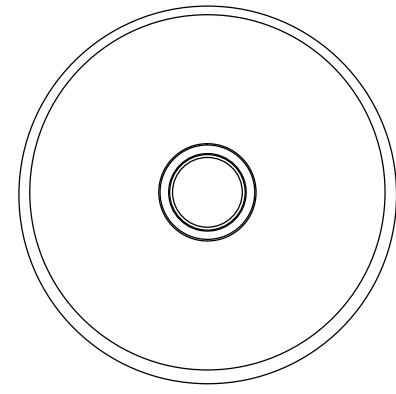

TOP VIEW

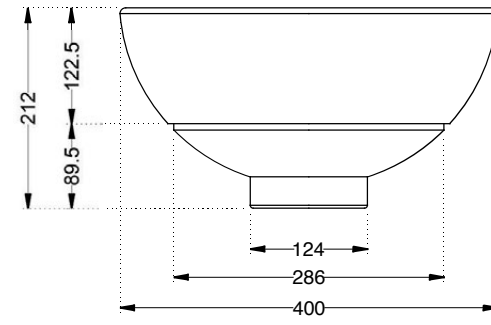

FRONT VIEW

Bowl 450

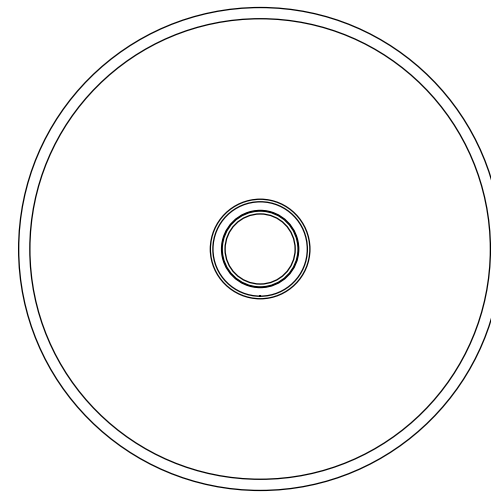

TOP VIEW

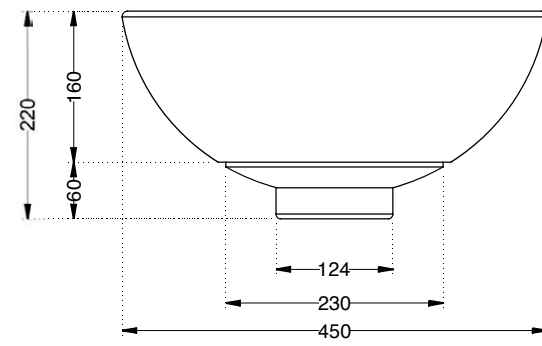

FRONT VIEW

LAVELLI IN CORIAN

Universal 14

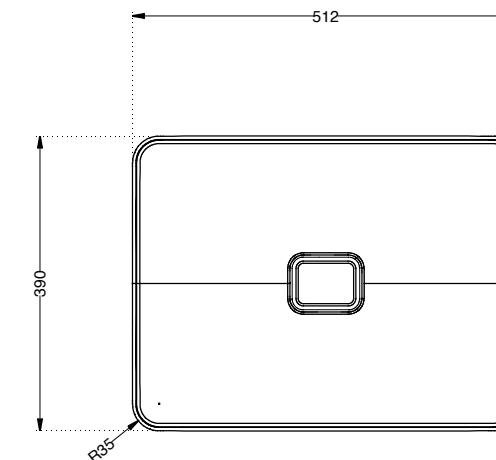

TOP VIEW

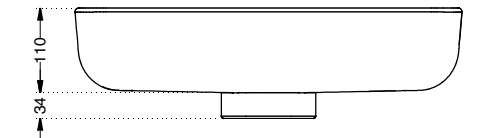

FRONT VIEW

Universal 15

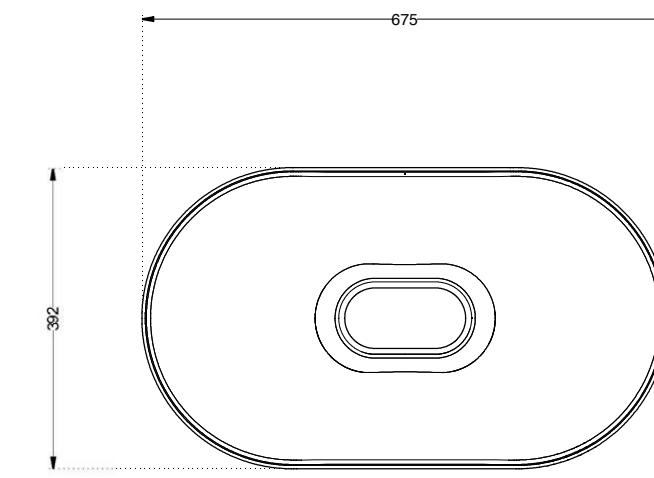

TOP VIEW

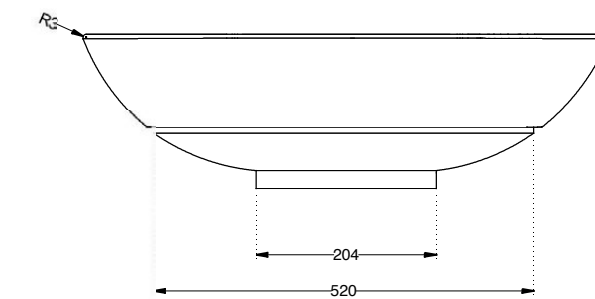

FRONT VIEW

## LAVELLI IN CORIAN

Freestanding rectangular

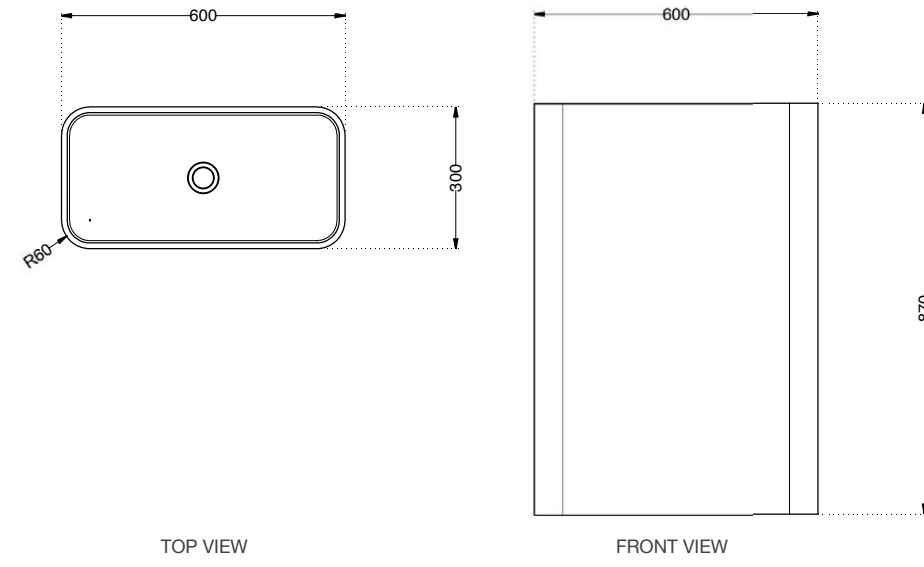

Sink at wall

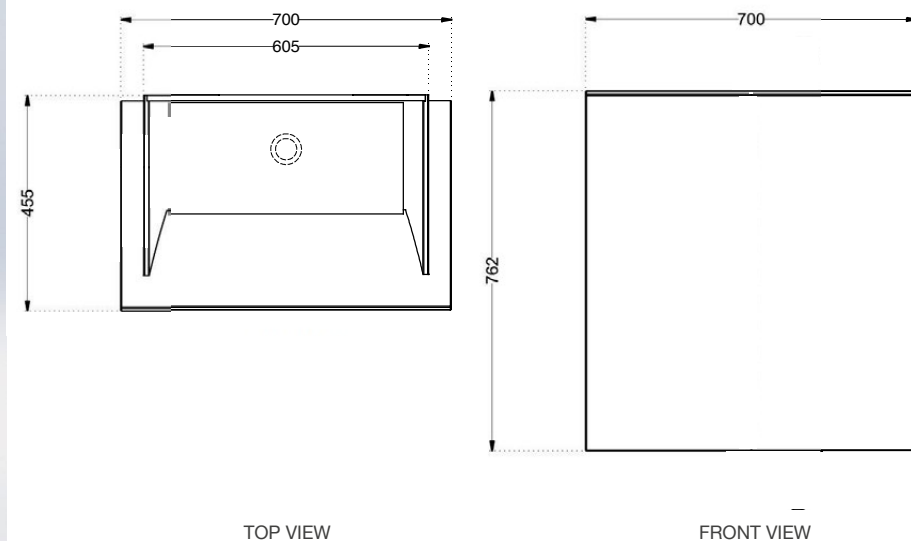
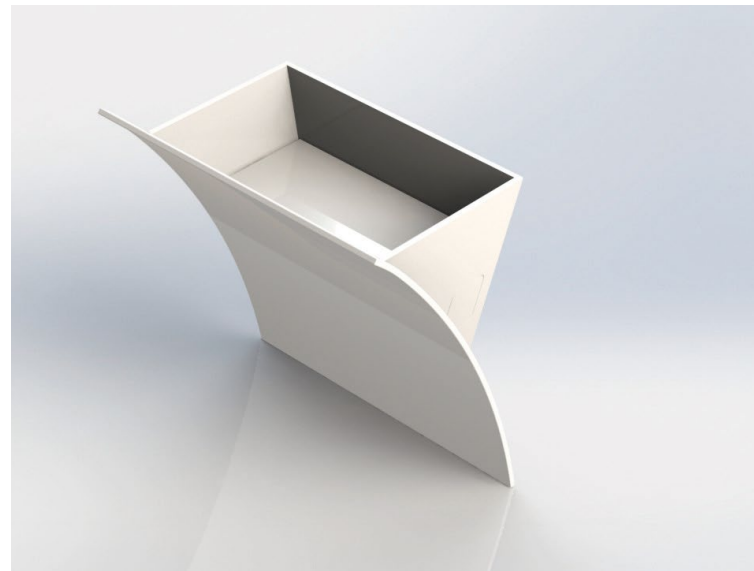

## ELEMENTI IN CORIAN

Shower flush floor

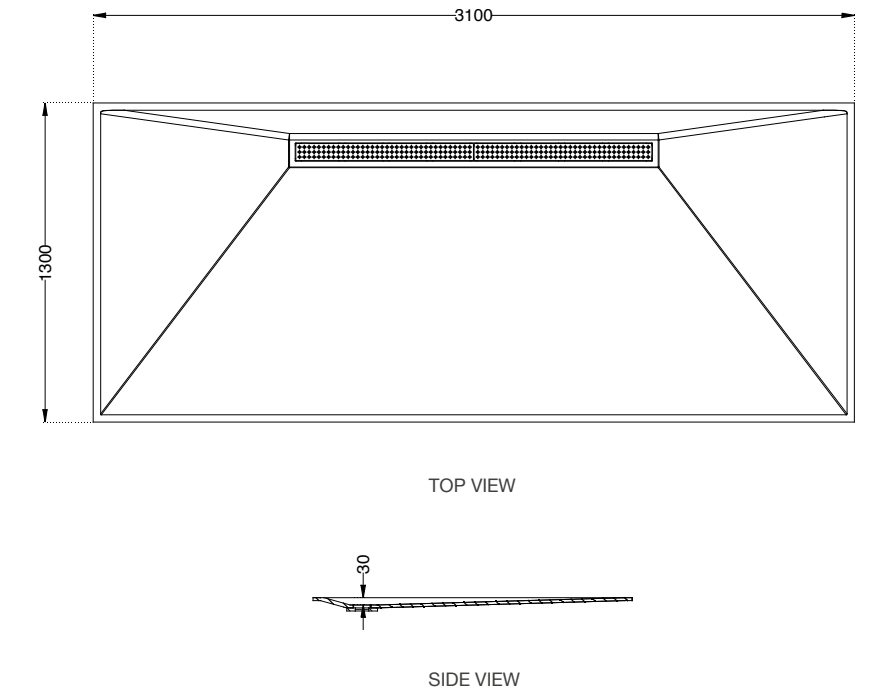

# LAVELLI IN CERAMICA



**veronnesi**  
authentic italian craftsmanship

# LAVELLI IN CERAMICA

Blat

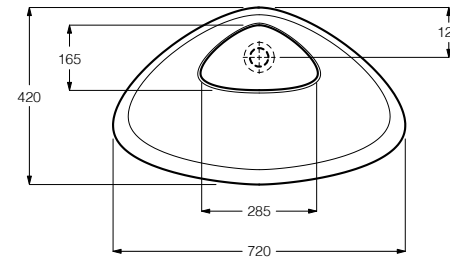

TOP VIEW

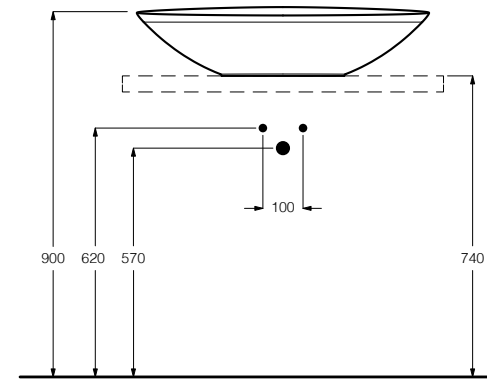

FRONT VIEW

Bly

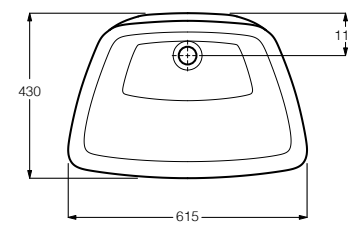

TOP VIEW

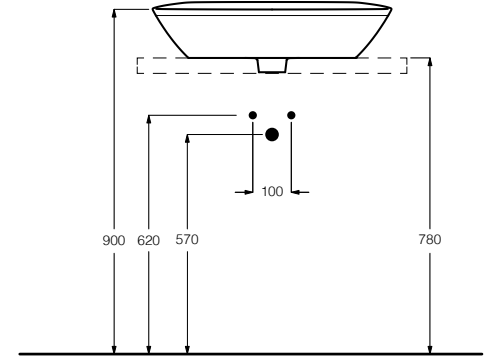

FRONT VIEW

# LAVELLI IN CERAMICA

Clo

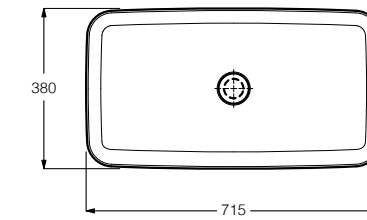

TOP VIEW

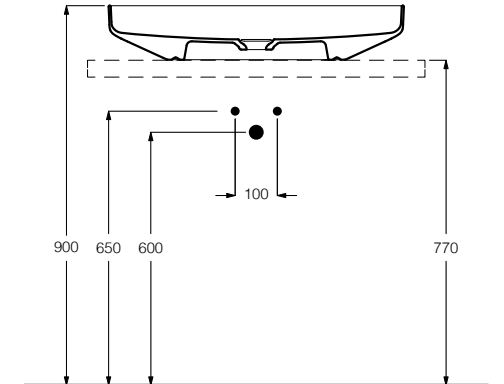

FRONT VIEW

Livia

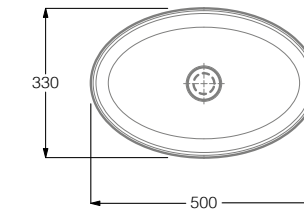

TOP VIEW

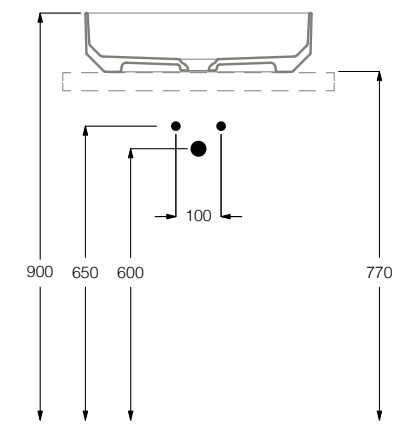

FRONT VIEW

# LAVELLI IN CERAMICA

Ode

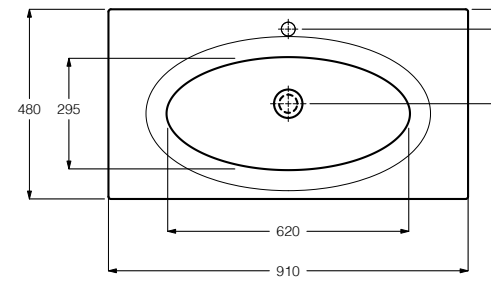

TOP VIEW

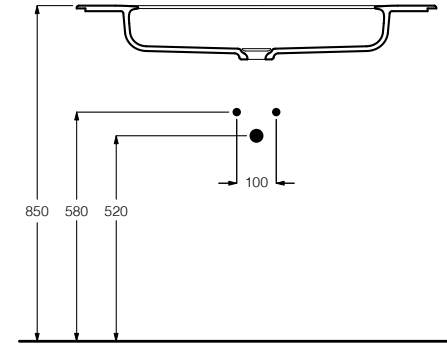

FRONT VIEW

Pit

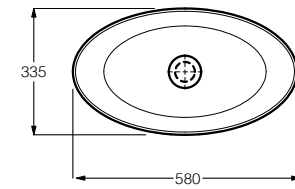

TOP VIEW

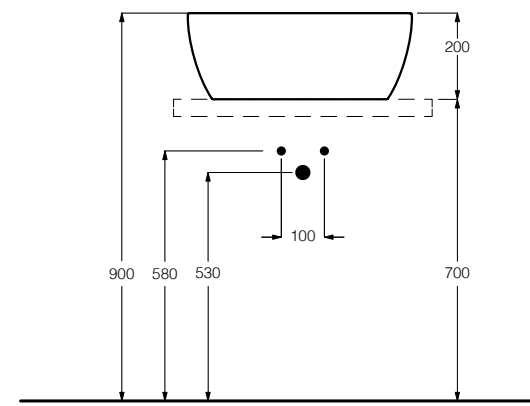

FRONT VIEW

# LAVELLI IN CERAMICA

Ulm

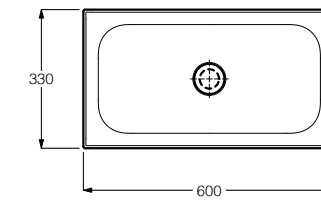

TOP VIEW

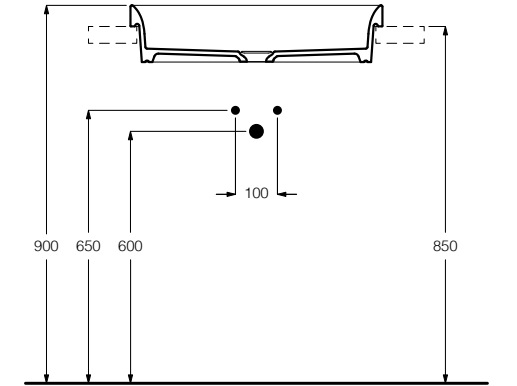

FRONT VIEW



VIA S. MARIA S. N. 61046 PIOBBICO (PU)  
ITALY